

THIS DRAWING IS SUPPLIED FOR INFORMATION ONLY. DESIGN FEATURES, SPECIFICATIONS AND PERFORMANCE DATA SHOWN HEREON ARE THE PROPERTY OF THE AMPHENOL CORPORATION. NO RIGHTS OF REPRODUCTION ARE IMPLIED. ALL DIMENSIONS ARE SUBJECT TO NORMAL MANUFACTURING VARIATIONS.

REVISIONS					
REV	ECN	DESCRIPTION	BY	APPR	DATE
01	--	INITIAL RELEASE	Jenson	Bill	09/20/2018

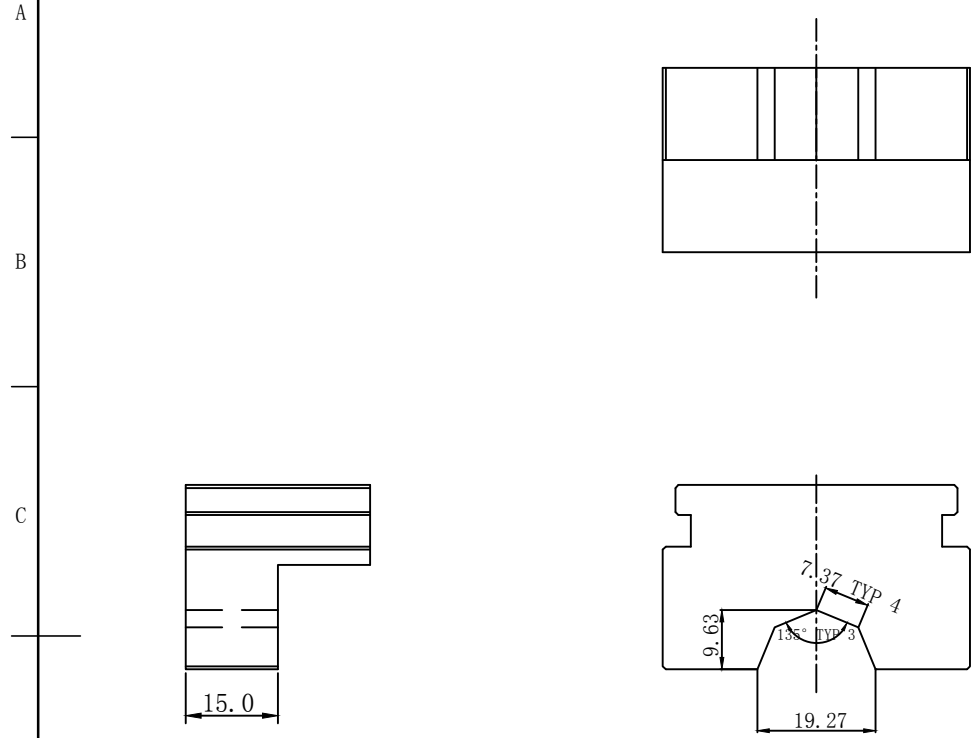

upper die
上模

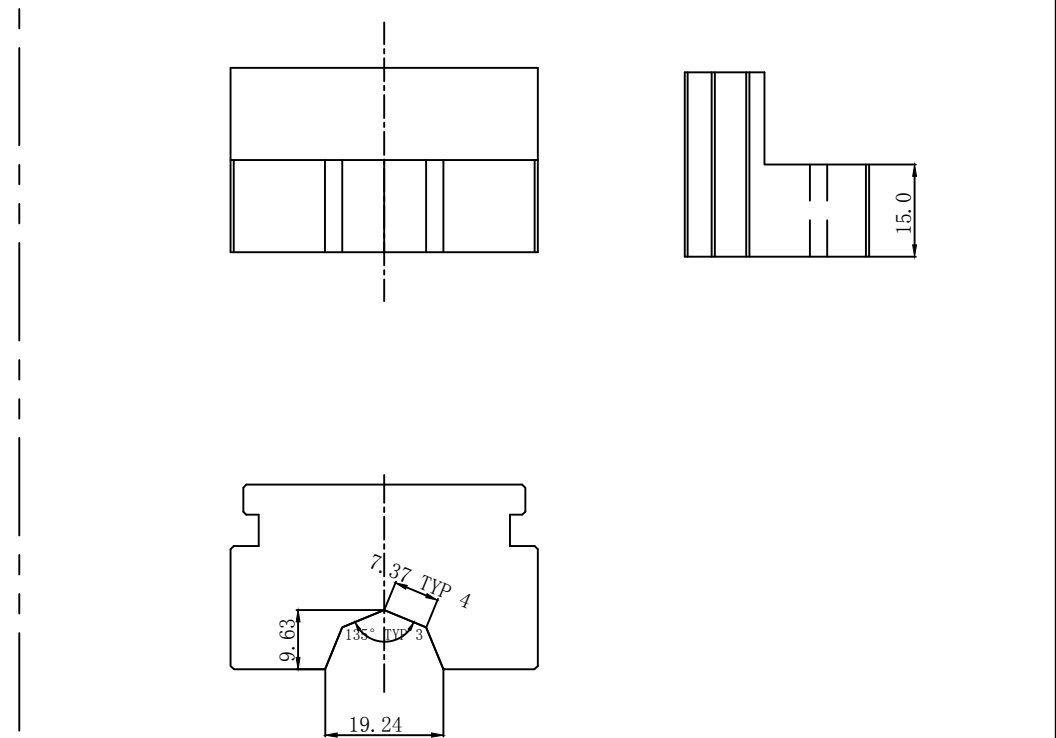

lower die
下模

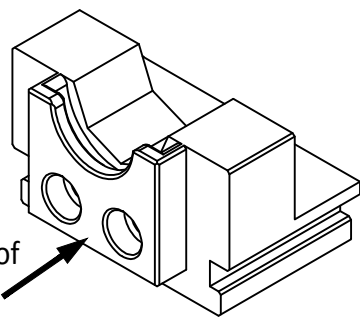

It is recommended to add a copper sleeve locating block to the lower die of the jig, as shown in the right figure

建议在压接治具的下模上增加一个铜套定位块，如右图所示

NOTE :
The crimping die for the No.84096257 HS shielded cable (50mm²)
注意：
压接模适用于编号84096257 的HS 屏蔽线缆（50平方）

		Amphenol Technical Products International GZ				PART NAME:	
		第一角投影 FIRST ANGLE PROJECTION	页面 SHEET	幅面 SIZE	版次 REV.	比例 SCALE	Crimping die for the 50mm ² copper ring of Gen II
签名 SIGNATURE		日期 DATE		UNLESS OTHERWISE SPECIFIED		DWG NO:	
制图 DRAWN	Jenson	09/20/2018		1) All dimensions are in metric(mm). 2) Tolerances are as follows: 1 PL DEC ±0.05 2 PL DEC ±0.02 3 PL DEC ±0.01		195195150D50	
审核 CHECKED				Surf texture: 1.6 ✓ Angles ±30'		CUST PART #:	CUST REV.:
批准 APPROVAL						--	--