

THIS DRAWING IS SUPPLIED FOR INFORMATION ONLY. DESIGN FEATURES, SPECIFICATIONS AND PERFORMANCE DATA SHOWN HEREON ARE THE PROPERTY OF THE AMPHENOL CORPORATION. NO RIGHTS OF REPRODUCTION ARE IMPLIED. ALL DIMENSIONS ARE SUBJECT TO NORMAL MANUFACTURING VARIATIONS.

**Customer Drawing**

**订购信息 Ordering Information**

PL58 X - 30 1 - 70		
<b>键位及颜色 Key &amp; Color</b>	<b>高压互锁 HVIL</b>	<b>线缆大小 Cable Size</b>
"X", 橙色 Orange	0, 不带互锁 No HVIL	"70"=70mm <sup>2</sup>
"Y", 黑色 Black	1, 带互锁 With HVIL	"50"=50mm <sup>2</sup>
"U", 黄色 Yellow		"35"=35mm <sup>2</sup>
"V", 绿色 Green		
"W", 红色 Red		
"T", 蓝色 Blue		

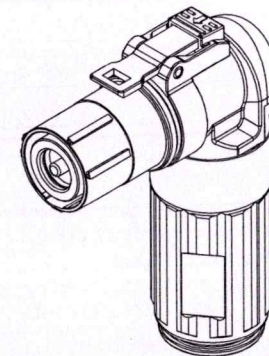
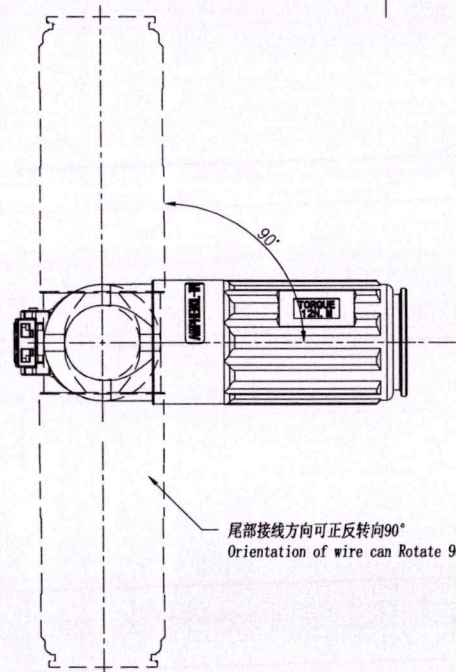

按键颜色见“订购信息”  
The color of press key see "Ordering Information"

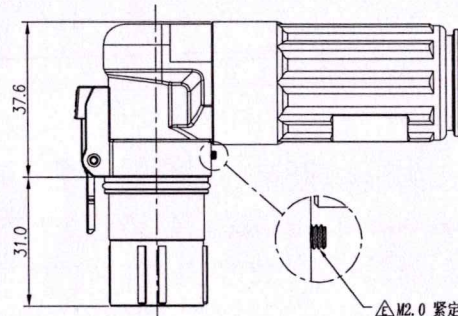
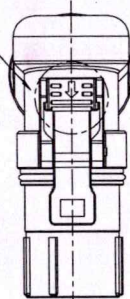

P/N	Model NO.	Accepted Wire OD
AC-HA004440	PL58X-301-35	11.5±0.3
AC-HA004441	PL58Y-301-35	
AC-HA004442	PL58U-301-35	
AC-HA004443	PL58V-301-35	
AC-HA004444	PL58W-301-35	
AC-HA004445	PL58X-301-50	13.6±0.3
AC-HA004446	PL58Y-301-50	
AC-HA004447	PL58U-301-50	
AC-HA004448	PL58V-301-50	
AC-HA004449	PL58W-301-50	
AC-HA004450	PL58X-301-70	15.5±0.3
AC-HA004451	PL58Y-301-70	
AC-HA004452	PL58U-301-70	
AC-HA004453	PL58V-301-70	
AC-HA004454	PL58W-301-70	

P/N	Model NO.	Accepted Wire OD
AC-HA004455	PL58X-300-35	11.5±0.3
AC-HA004456	PL58Y-300-35	
AC-HA004457	PL58U-200-35	
AC-HA004458	PL58V-300-35	
AC-HA004459	PL58W-300-35	
AC-HA003745	PL58X-300-50	13.6±0.3
AC-HA003746	PL58Y-300-50	
AC-HA003747	PL58U-300-50	
AC-HA003748	PL58V-300-50	
AC-HA003749	PL58W-300-50	
AC-HA004460	PL58X-300-70	15.5±0.3
AC-HA004461	PL58Y-300-70	
AC-HA004462	PL58U-300-70	
AC-HA004463	PL58V-300-70	
AC-HA004464	PL58W-300-70	

**规格参数 (Spec.):**

- 工作温度 Operating temperature: -40° C~+125° C.
- 额定电流 Current rating (Connector Only):  
35mm<sup>2</sup>:150A; 50mm<sup>2</sup>:200A; 70mm<sup>2</sup>:250A; 95mm<sup>2</sup>:300A. ⚠
- 额定电压 Operating voltage:1000 VDC.
- 耐电压 Dielectric withstanding voltage: 5000 VDC.
- 防护等级 Protection class:IP67 & IP2X.
- 电磁屏蔽 Shielding.
- 机械寿命 Mating cycle:100 Min.
- 带自动二次锁扣 Automatic secondary lock.
- 尾部接线方向可正反转90° Rotate function of wire.
- 带高压互锁 Electrical interlock (HVIL).
- 配对插座 Mating receptacle : See drawing "PL00-300"
- 紧固螺丝锁紧扭矩 Tightening Torque of Locking Screw: 0.17±0.01 Nm ⚠

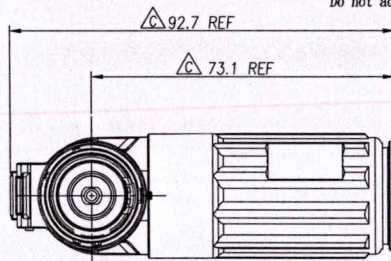

⚠ M2.0 紧固螺丝  
M2.0 locking screw  
组装线束时需涂螺纹胶后锁紧, 标准件出货不涂螺纹胶  
Add thread glue here and tighten the nut when it is used in cable assembly  
Do not add glue when it is used in standard part

REVISIONS						
REV	ZONE	ECO	DESCRIPTION	DATE	BY	APPR
A	---	---	INITIAL RELEASE	06/24/15	RW	EC
B	---	---	The Locking Screw Change from M2.5 to M2.0	03/25/16	RW	GX
C	---	---	Change back shell	09/29/16	RW	TS
D	---	---	Add Locking Screw Assembly Torque	10/28/16	SW	RW
E	---	---	Updated Spec.	11/29/19	Steven	JL

		<b>Amphenol Technical Products International GZ</b>				PART NAME: PwrLok 10mm-90 1POS Plug Assy	
		第三角投影 THIRD ANGLE PROJECTION	页码 SHEET 1 of 1	幅面 SIZE A3	版次 REV. E	比例 SCALE	DWG NO: PL58-300
签名 SIGNATURE Steven		日期 DATE 11/29/19		UNLESS OTHERWISE SPECIFIED 1) All dimensions are in metric (mm). 2) Tolerances are as follows: 0 PL DEC ±1.00 1 PL DEC ±0.50 2 PL DEC ±0.20		CUST PART #: N/A	
制图 DRAWN Steven		审核 CHECKED Steven		批准 APPROVAL Steven		Angles ±1°	

THIS DRAWING IS SUPPLIED FOR INFORMATION ONLY. DESIGN FEATURES, SPECIFICATIONS AND PERFORMANCE DATA SHOWN HEREON ARE THE PROPERTY OF THE AMPHENOL CORPORATION. NO RIGHTS OF REPRODUCTION ARE IMPLIED. ALL DIMENSIONS ARE SUBJECT TO NORMAL MANUFACTURING VARIATIONS.

Customer Drawing

订购信息 Ordering Information

PL58 X - 30 1 - 70

键位及颜色 Key & Color	高压互锁 HVIL	线缆大小 Cable Size
"X", 橙色 Orange	0, 不带互锁 No HVIL	"70"=70mm <sup>2</sup>
"Y", 黑色 Black	1, 带互锁 With HVIL	"50"=50mm <sup>2</sup>
"U", 黄色 Yellow		"35"=35mm <sup>2</sup>
"V", 绿色 Green		
"W", 红色 Red		
"T", 蓝色 Blue		

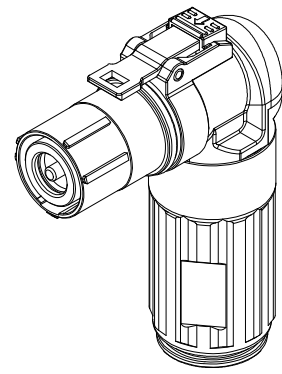
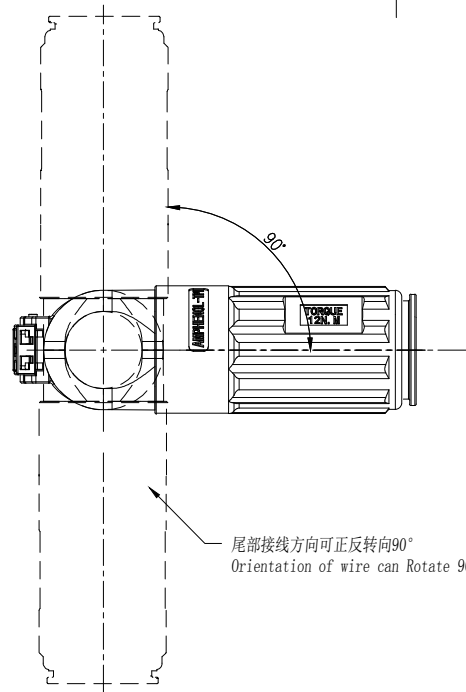

REVISIONS						
REV	ZONE	ECO	DESCRIPTION	DATE	BY	APPR
A	--	--	INITIAL RELEASE	06/24/15	RW	EC
B	--	--	The Locking Screw Change from M2.5 to M2.0	03/25/16	RW	GX
C	--	--	Change back shell	09/29/16	RW	TS
D	--	--	Add Locking Screw Assembly Torque	10/28/16	SW	RW
E	--	--	Updated Spec.	11/29/19	Steven	JL

按键颜色见“订购信息”  
The color of press key see "Ordering Information"

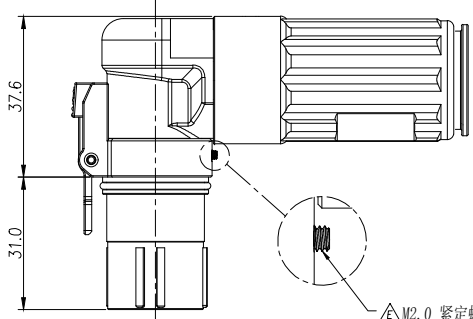
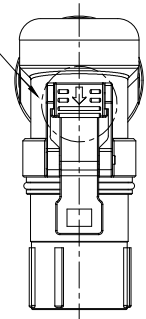

P/N	Model NO.	Accepted Wire OD
AC-HA004440	PL58X-301-35	11.5±0.3
AC-HA004441	PL58Y-301-35	
AC-HA004442	PL58U-301-35	
AC-HA004443	PL58V-301-35	
AC-HA004444	PL58W-301-35	
AC-HA004445	PL58X-301-50	13.6±0.3
AC-HA004446	PL58Y-301-50	
AC-HA004447	PL58U-301-50	
AC-HA004448	PL58V-301-50	
AC-HA004449	PL58W-301-50	
AC-HA004450	PL58X-301-70	15.5±0.3
AC-HA004451	PL58Y-301-70	
AC-HA004452	PL58U-301-70	
AC-HA004453	PL58V-301-70	
AC-HA004454	PL58W-301-70	

P/N	Model NO.	Accepted Wire OD
AC-HA004455	PL58X-300-35	11.5±0.3
AC-HA004456	PL58Y-300-35	
AC-HA004457	PL58U-300-35	
AC-HA004458	PL58V-300-35	
AC-HA004459	PL58W-300-35	
AC-HA003745	PL58X-300-50	13.6±0.3
AC-HA003746	PL58Y-300-50	
AC-HA003747	PL58U-300-50	
AC-HA003748	PL58V-300-50	
AC-HA003749	PL58W-300-50	
AC-HA004460	PL58X-300-70	15.5±0.3
AC-HA004461	PL58Y-300-70	
AC-HA004462	PL58U-300-70	
AC-HA004463	PL58V-300-70	
AC-HA004464	PL58W-300-70	

规格参数 (Spec.):

- 工作温度 Operating temperature: -40° C~+125° C.
- 额定电流 Current rating (Connector Only):  
35mm<sup>2</sup>:150A; 50mm<sup>2</sup>:200A; 70mm<sup>2</sup>:250A; 95mm<sup>2</sup>:300A. △
- 额定电压 Operating voltage:1000 VDC.
- 耐电压 Dielectric withstanding voltage: 5000 VDC.
- 防护等级 Protection class:IP67 & IP2X.
- 电磁屏蔽 Shielding.
- 机械寿命 Mating cycle:100 Min.
- 带自动二次锁扣 Automatic secondary lock.
- 尾部接线方向可正反转向90° Rotate function of wire.
- 带高压互锁 Electrical interlock (HVIL).
- 配对插座 Mating receptacle : See drawing "PL00-300"
- 拧紧螺丝锁紧扭矩 Tightening Torque of Locking Screw: 0.17±0.01 Nm △

△M2.0 锁定螺丝  
M2.0 locking screw  
组装线束时需涂螺纹胶后锁紧, 标准件出货不涂螺纹胶  
Add thread glue here and tighten the nut When it is used in cable assembly  
Do not add glue when it is used in standard part

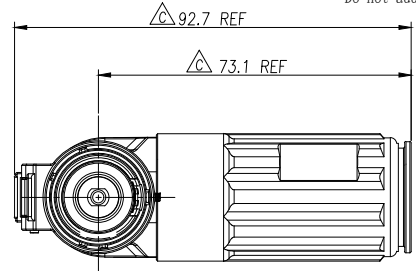

	Amphenol Technical Products International GZ					PART NAME: PwrLok 10mm-90 1POS Plug Assy	
	第三角投影 THIRD ANGLE PROJECTION	页面 SHEET	幅面 SIZE	版次 REV.	比例 SCALE	DWG NO: PL58-300	
签名 SIGNATURE Steven		日期 DATE 11/29/19		UNLESS OTHERWISE SPECIFIED 1) All dimensions are in metric(mm). 2) Tolerances are as follows: 0 PL DEC ±1.00 1 PL DEC ±0.50 2 PL DEC ±0.20		CUST PART #: N/A	
制图 DRAWN		审核 CHECKED		批准 APPROVAL		CUST REV. -	