

THIS DRAWING IS SUPPLIED FOR INFORMATION ONLY. DESIGN FEATURES, SPECIFICATIONS AND PERFORMANCE DATA SHOWN HEREON ARE THE PROPERTY OF THE AMPHENOL CORPORATION. NO RIGHTS OF REPRODUCTION ARE IMPLIED. ALL DIMENSIONS ARE SUBJECT TO NORMAL MANUFACTURING VARIATIONS.

Customer Drawing

REVISIONS						
REV	ZONE	ECO	DESCRIPTION	DATE	BY	APPR
A	--	--	INITIAL RELEASE	11/04/13	RW	EC
B	--	--	Updated dimensions	08/22/14	RW	EC
C	--	--	Change Appearance	12/08/15	RW	GX
D	--	--	change strain relief	03/26/18	KW	JG
E	--	--	Update Spec	01/08/19	Fred	JL

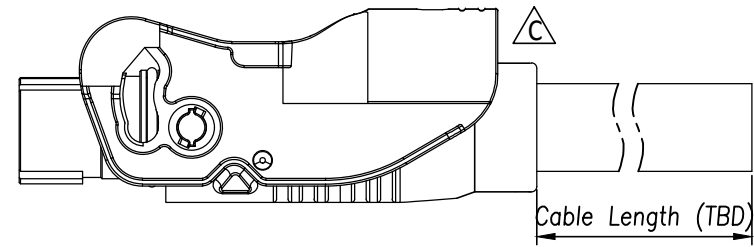
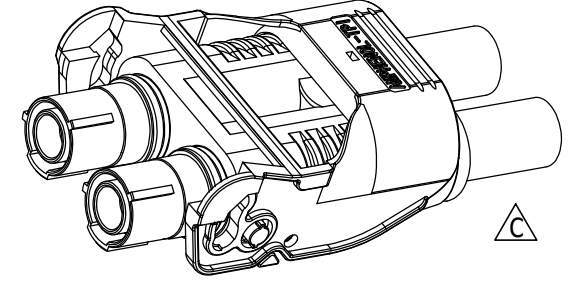
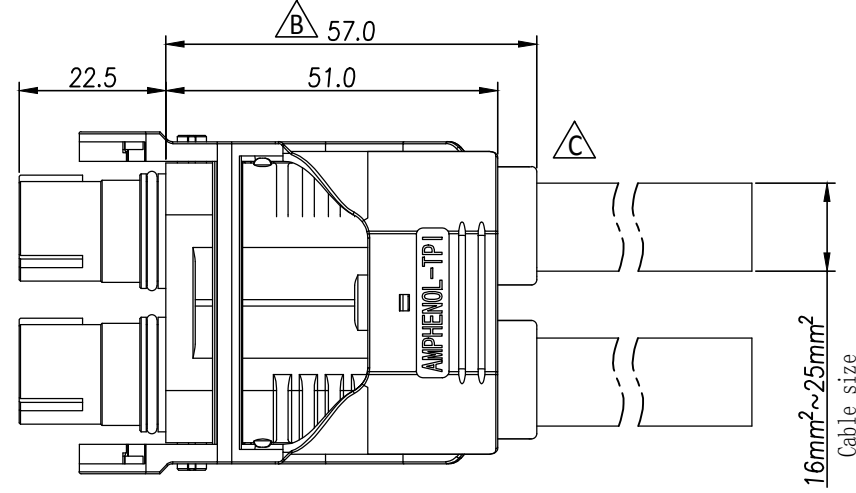
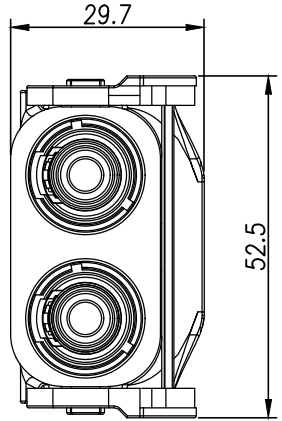

订购信息 Ordering Information

PL102	X	-	12	0	-	25
键位及颜色 Key & Color	高压互锁 HVIL	线缆大小 Cable Size				
"X", 橙色 Orange	0, 不带互锁 No HVIL	"25"=25mm ²				
"Y", 黑色 Black	1, 带互锁 With HVIL	"16"=16mm ²				

规格参数 (Spec.):

1. 工作温度 Operating temperature: -40° C~+125° C.
2. 额定电流 Current rating (Connector Only):
16mm²: 90 A; 25mm²: 120 A. △E
3. 额定电压 Operating voltage: 1000 VDC.
4. 耐电压 Dielectric withstanding voltage: 5000 VDC.
5. 防护等级 Protection class: IP67.
6. 电磁屏蔽 Shielding.
7. 机械寿命 Mating cycle: 100 Min. △E
8. 带自动二次锁扣 Automatic secondary lock.
9. 带高压互锁 Electrical interlock (HVIL).

	Amphenol Technical Products International GZ				
	第三角投影 THIRD ANGLE PROJECTION	页面 SHEET	幅面 SIZE	版次 REV.	比例 SCALE
签名 SIGNATURE	日期 DATE	UNLESS OTHERWISE SPECIFIED			DWG NO:
制图 DRAWN	Fred	1) All dimensions are in metric (mm). 2) Tolerances are as follows:			PL102-120
审核 CHECKED		0 PL DEC ±1.00 1 PL DEC ±0.50 2 PL DEC ±0.20			CUST PART #:
批准 APPROVAL		Angles ±1°			N/A
					CUST REV.:
					-

THIS DRAWING IS SUPPLIED FOR INFORMATION ONLY. DESIGN FEATURES, SPECIFICATIONS AND PERFORMANCE DATA SHOWN HEREON ARE THE PROPERTY OF THE AMPHENOL CORPORATION. NO RIGHTS OF REPRODUCTION ARE IMPLIED. ALL DIMENSIONS ARE SUBJECT TO NORMAL MANUFACTURING VARIATIONS.

Customer Drawing

REVISIONS						
REV	ZONE	ECO	DESCRIPTION	DATE	BY	APPR
A	---	---	INITIAL RELEASE	11/04/13	RW	EC
B	---	---	Updated dimensions	08/22/14	RW	EC
C	---	---	Change Appearance	12/08/15	RW	GX
D	---	---	change strain relief	03/26/18	KW	JG
E	---	---	Update Spec	01/08/19	Fred	JL

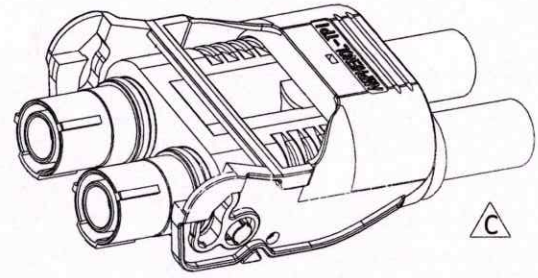
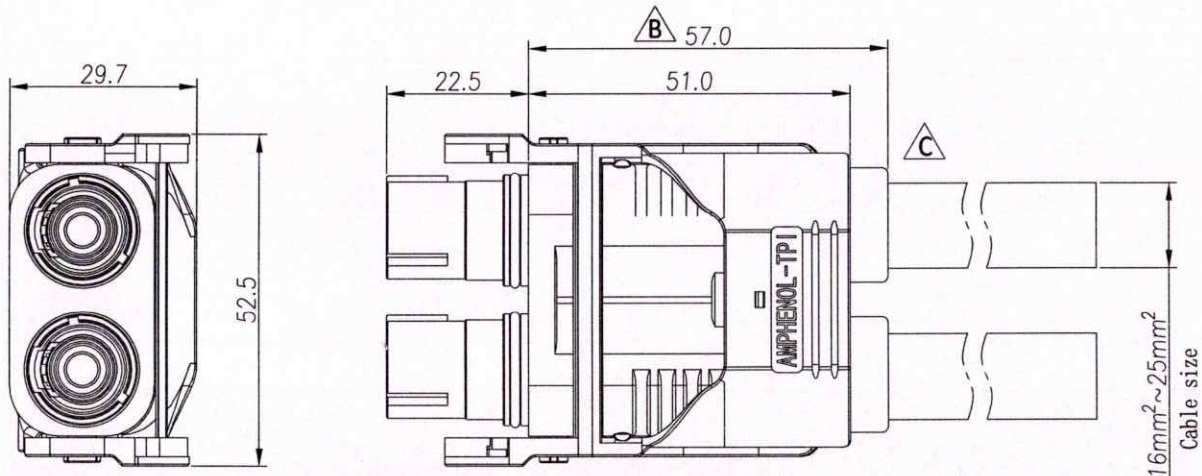

Amphenol TPI
2019-04-08
REGISTERED COPY

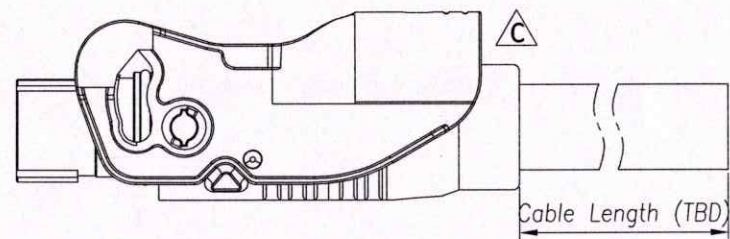

订购信息 Ordering Information

PL102			X	-	12	0	-	25
键位及颜色 Key & Color		高压互锁 HVIL		线缆大小 Cable Size				
"X", 橙色 Orange		0, 不带互锁 No HVIL		"25"=25mm ²				
"Y", 黑色 Black		1, 带互锁 With HVIL		"16"=16mm ²				

规格参数 (Spec.):

1. 工作温度 Operating temperature: -40° C~+125° C.
2. 额定电流 Current rating (Connector Only):
16mm²: 90 A; 25mm²: 120 A. △
3. 额定电压 Operating voltage: 1000 VDC.
4. 耐电压 Dielectric withstanding voltage: 5000 VDC.
5. 防护等级 Protection class: IP67.
6. 电磁屏蔽 Shielding.
7. 机械寿命 Mating cycle: 100 Min. △
8. 带自动二次锁扣 Automatic secondary lock.
9. 带高压互锁 Electrical interlock (HVIL).

	Amphenol Technical Products International GZ					PART NAME:	
	第三角投影 THIRD ANGLE PROJECTION	页 面 SHEET	幅 面 SIZE	版 次 REV.	比 例 SCALE	PwrLok 5.7mm 2POS Plug	
1 of 1		A3	E			DWG NO:	
日期 DATE		UNLESS OTHERWISE SPECIFIED				PL102-120	
1) All dimensions are in metric (mm).		2) Tolerances are as follows:				CUST PART #:	
0 PL DEC ±1.00		1 PL DEC ±0.50				N/A	
2 PL DEC ±0.20		Angles ±1°				CUST REV:	
签 名 SIGNATURE		日期 DATE					
制 图 DRAWN		日期 DATE					
审 核 CHECKED		日期 DATE					
批 准 APPROVAL		日期 DATE					