

THIS DRAWING IS SUPPLIED FOR INFORMATION ONLY. DESIGN FEATURES, SPECIFICATIONS AND PERFORMANCE DATA SHOWN HEREON ARE THE PROPERTY OF THE AMPHENOL CORPORATION. NO RIGHTS OF REPRODUCTION ARE IMPLIED. ALL DIMENSIONS ARE SUBJECT TO NORMAL MANUFACTURING VARIATIONS.

Customer Drawing

REV		ZONE	ECO	DESCRIPTION	DATE	BY	APPR
				REVISIONS			
A	--	--	--	INITIAL RELEASE	01/09/15	RW	EC
B	--	--	--	Add fasten torque on rear stud and flange	08/14/15	RW	TS
C	--	--	--	Add rib feature on the gasket	08/20/15	RW	GX
D	--	--	--	Add part number	12/05/17	Sam	Julie
E	--	--	--	Update spec.	11/27/18	Fred	JL

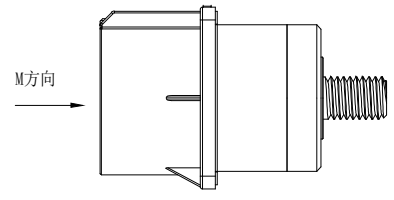
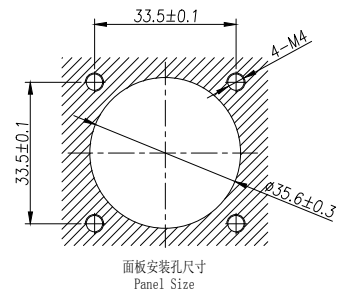
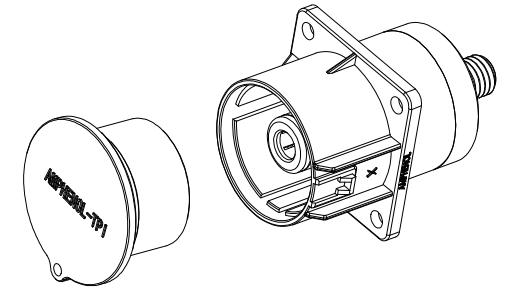
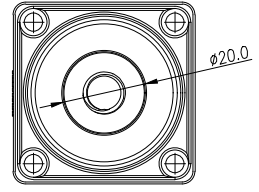
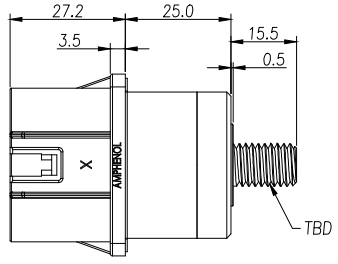
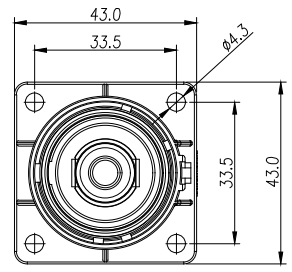

Standard Part List

P/N	Model NO.	Polarization
AC-HA000578	PL00X-500-20M8	X
AC-HA000579	PL00Y-500-20M8	Y
AC-HA000580	PL00U-500-20M8	U
AC-HA000581	PL00V-500-20M8	V
AC-HA000582	PL00W-500-20M8	W
AC-HA000583	PL00X-500-20M10	X
AC-HA000584	PL00Y-500-20M10	Y
AC-HA000585	PL00U-500-20M10	U
AC-HA000586	PL00V-500-20M10	V
AC-HA000587	PL00W-500-20M10	W

- 规格参数 (Spec.):
1. 工作温度 Operating temperature: -40° C~+125° C.
 2. 额定电流 Current rating: 500 A.
 3. 额定电压 Operating voltage: 1000 VDC.
 4. 耐电压 Dielectric withstanding voltage: 5000 VDC.
 5. 防护等级 Protection class: IP67 & IP2X.
 6. 电磁屏蔽 Shielding.
 7. 机械寿命 Mating cycle: 100 Min.
 8. 带自动二次锁扣 Automatic secondary lock.
 9. 铜排推荐安装扭矩 Recommended Fasten Torque on Rear Stud:
 - M6 : 3.6~4.4 Nm
 - M8 : 7.2~8.8 Nm
 - M10: 17.1~20.9 Nm
 10. 法兰盘螺丝安装扭矩 Screw Assembly Torque on Flange : 1.6~2.4 Nm

订购信息 Ordering Information

PL00 X - 50 0 - 20 M10

键位及颜色 Key & Color	高压互锁 HVIL	螺纹 Thread
"X", 橙色 Orange	0, 不带互锁 No HVIL	M8
"Y", 黑色 Black		M10
"U", 黄色 Yellow		
"V", 绿色 Green		
"W", 红色 Red		

	Amphenol Technical Products International GZ				
	第三角投影 THIRD ANGLE PROJECTION	页面 SHEET	幅面 SIZE	版次 REV.	比例 SCALE
1 OF 1	A3	E			DWG NO: PL00-500-20
签名 SIGNATURE Fred	日期 DATE 11/27/18	UNLESS OTHERWISE SPECIFIED 1) All dimensions are in metric(mm). 2) Tolerances are as follows: 0 PL DEC ±1.00 1 PL DEC ±0.50 2 PL DEC ±0.20			CUST PART #: N/A
制图 DRAWN	审核 CHECKED	批准 APPROVAL	日期 DATE	比例 SCALE	CUST REV. -

THIS DRAWING IS SUPPLIED FOR INFORMATION ONLY. DESIGN FEATURES, SPECIFICATIONS AND PERFORMANCE DATA SHOWN HEREON ARE THE PROPERTY OF THE AMPHENOL CORPORATION. NO RIGHTS OF REPRODUCTION ARE IMPLIED. ALL DIMENSIONS ARE SUBJECT TO NORMAL MANUFACTURING VARIATIONS.

Customer Drawing

Amphenol TPI
2018-11-27
REGISTERED COPY

REVISIONS						
REV	ZONE	ECO	DESCRIPTION	DATE	BY	APPR
A	--	--	INITIAL RELEASE	01/09/15	RW	EC
B	--	--	Add fasten torque on rear stud and flange	08/14/15	RW	TS
C	--	--	Add rib feature on the gasket	08/20/15	RW	GX
D	--	--	Add part number	12/05/17	Sam	Julie
E	--	--	Update spec.	11/27/18	Fred	JL

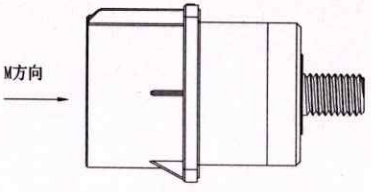
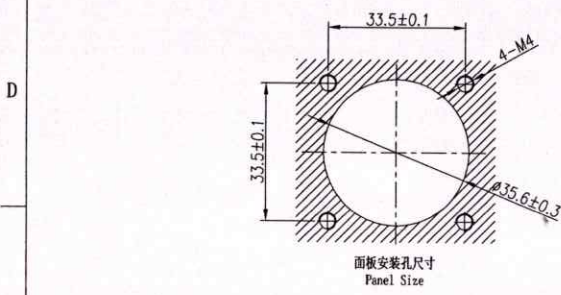
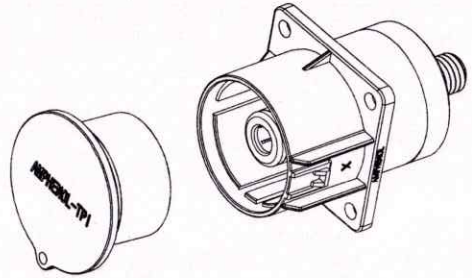
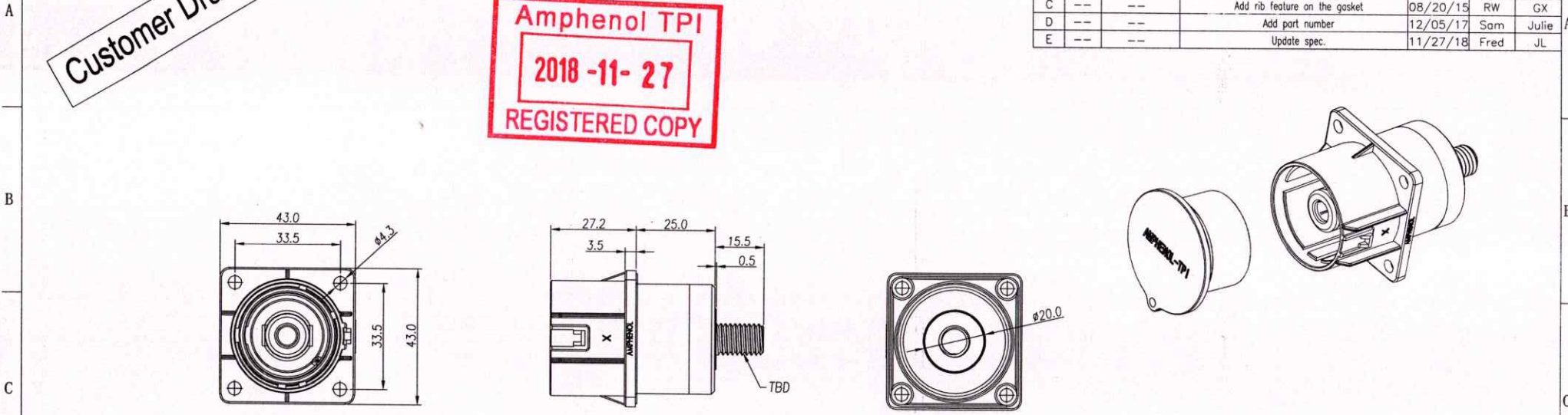

Standard Part List

P/N	Model NO.	Polarization
AC-HA000578	PL00X-500-20M8	X
AC-HA000579	PL00Y-500-20M8	Y
AC-HA000580	PL00U-500-20M8	U
AC-HA000581	PL00V-500-20M8	V
AC-HA000582	PL00W-500-20M8	W
AC-HA000583	PL00X-500-20M10	X
AC-HA000584	PL00Y-500-20M10	Y
AC-HA000585	PL00U-500-20M10	U
AC-HA000586	PL00V-500-20M10	V
AC-HA000587	PL00W-500-20M10	W

- 规格参数 (Spec.):
1. 工作温度 Operating temperature: -40° C~+125° C.
 2. 额定电流 Current rating: 500 A.
 3. 额定电压 Operating voltage: 1000 VDC.
 4. 耐电压 Dielectric withstanding voltage: 5000 VDC.
 5. 防护等级 Protection class: IP67 & IP2X.
 6. 电磁屏蔽 Shielding.
 7. 机械寿命 Mating cycle: 100 Min. Δ
 8. 带自动二次锁扣 Automatic secondary lock.
 9. 铜排推荐安装扭矩 Recommended Fasten Torque on Rear Stud:
M6 : 3.6~4.4 Nm
M8 : 7.2~8.8 Nm
M10: 17.1~20.9 Nm
 10. 法兰盘螺丝安装扭矩 Screw Assembly Torque on Flange : 1.6~2.4 Nm

订购信息 Ordering Information

PL00 X - 50 0 - 20 M10

键位及颜色 Key & Color	高压互锁 HVIL	螺纹 Thread
"X", 橙色 Orange	0, 不带互锁 No HVIL	M8
"Y", 黑色 Black		M10
"U", 黄色 Yellow		
"V", 绿色 Green		
"W", 红色 Red		

	Amphenol Technical Products International GZ				PART NAME: PwrLok 14mm 1POS Rcpt Thread	
	第三角投影 THIRD ANGLE PROJECTION	页 面 SHEET	幅 面 SIZE	版 次 REV.	比 例 SCALE	DWG NO.:
		1 of 1	A3	E		
签名 SIGNATURE		日期 DATE		UNLESS OTHERWISE SPECIFIED		
制图 DRAWN		11/27/18		1) All dimensions are in metric (mm).		
审核 CHECKED		11.27		2) Tolerances are as follows:		
批准 APPROVAL		2018.11.27		0 PL DEC ±1.00		
				1 PL DEC ±0.50		
				2 PL DEC ±0.20		
				Angles ±1°		
				CUST PART #:		N/A
				DWG NO.:		PL00-500-20
				CUST REV.:		-