

THIS DRAWING IS SUPPLIED FOR INFORMATION ONLY. DESIGN FEATURES, SPECIFICATIONS AND PERFORMANCE DATA SHOWN HEREON ARE THE PROPERTY OF THE AMPHENOL CORPORATION. NO RIGHTS OF REPRODUCTION ARE IMPLIED. ALL DIMENSIONS ARE SUBJECT TO NORMAL MANUFACTURING VARIATIONS.

Customer Drawing

REVISIONS						
REV	ZONE	ECO	DESCRIPTION	DATE	BY	APPR
A	--	--	INITIAL RELEASE	01/06/15	RW	EC
B	--	--	Add Protection Class: IP2X	05/05/15	RW	EC
C	--	--	Add Dust Cap & Change HVIL Wire, Update Spec.	03/29/16	RW	TS
D	--	--	Change Shell and Gasket	05/10/17	Sam	Julie

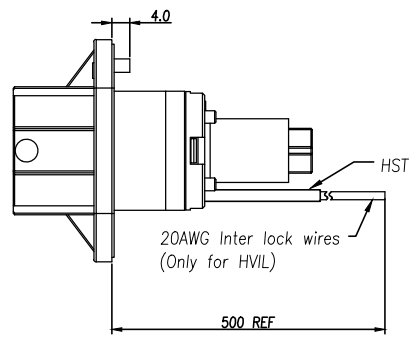
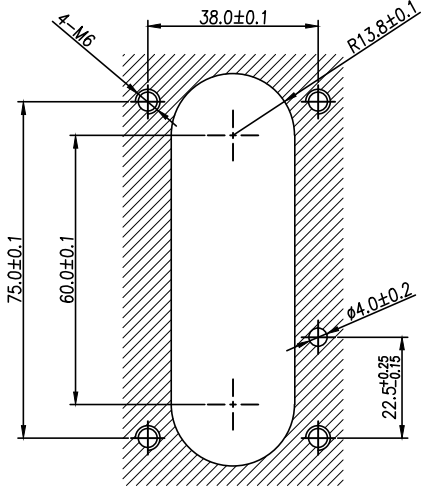
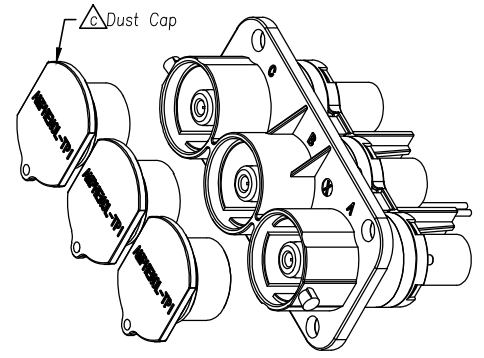
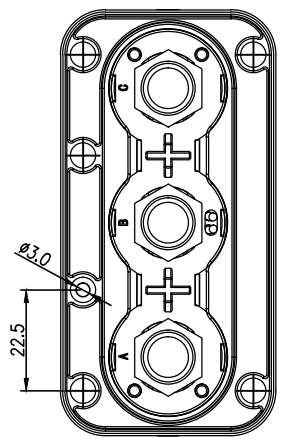
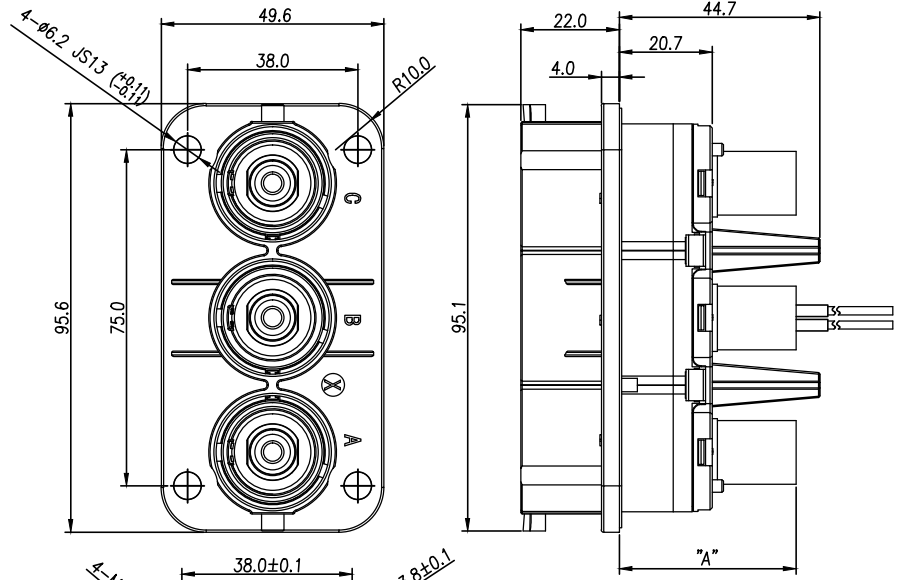

规格参数 (Spec.):

- 工作温度 Operating temperature: -40° C~+125° C.
- 带高压互锁 Electrical interlock (HVIL).
- 额定电流 Current rating: Power: 300A; HVIL: 5A.
- 额定电压 Operating voltage: Power: 1000 VDC; Signal: 60 VDC.
- 耐电压 Dielectric withstanding voltage:
 - 与插头对插后, Pin与铁壳之间 After matting, between pin and metal shell :5000 VDC.
 - 与插头对插后, Pin与HVIL之间 After matting, between pin and HVIL :5000 VDC.
 - 与插头对插后, HVIL与铁壳之间 After matting, between HVIL and metal shell :500 VDC.
 - 与插头对插前, 两个HVIL端子之间耐压 Before matting, between two HVIL terminals :500 VDC.
- 防护等级 Protection class: IP67 & IP2X.
- 电磁屏蔽 Shielding.
- 机械寿命 Mating cycle: 50 Min.
- 带自动二次锁扣 Automatic secondary lock.
- 推荐法兰盘螺丝安装扭矩 Recommended Screw Assembly Torque on Flange : 6.2*7.6 Nm

订购信息 Ordering Information

PL083 X - 30 1 - 30 D 70		
键位及颜色 Key "X" Key "Y" Key	高压互锁 HVIL 0, 不带互锁 No HVIL 1, 带互锁 With HVIL	线缆尺寸 Cable Size "70"=70mm ² "50"=50mm ² "35"=35mm ²

Standard Part List (With HVIL)

P/N	Model NO.	Mating Plug Model NO.	Dimension "A"
AC-HA001572	PL083X-301-30D35	PL183X-301-XX, PL283X-301-XX	36.4
AC-HA001573	PL083Y-301-30D35	PL183Y-301-XX, PL283Y-301-XX	36.4
AC-HA001574	PL083X-301-30D50	PL183X-301-XX, PL283X-301-XX	39.4
AC-HA001575	PL083Y-301-30D50	PL183Y-301-XX, PL283Y-301-XX	39.4
AC-HA001576	PL083X-301-30D70	PL183X-301-XX, PL283X-301-XX	39.4
AC-HA001577	PL083Y-301-30D70	PL183Y-301-XX, PL283Y-301-XX	39.4

Standard Part List (With Out HVIL)

P/N	Model NO.	Mating Plug Model NO.	Dimension "A"
AC-HA001578	PL083X-300-30D35	PL183X-300-XX, PL283X-300-XX	36.4
AC-HA001579	PL083Y-300-30D35	PL183Y-300-XX, PL283Y-300-XX	36.4
AC-HA001580	PL083X-300-30D50	PL183X-300-XX, PL283X-300-XX	39.4
AC-HA001581	PL083Y-300-30D50	PL183Y-300-XX, PL283Y-300-XX	39.4
AC-HA001582	PL083X-300-30D70	PL183X-300-XX, PL283X-300-XX	39.4
AC-HA001583	PL083Y-300-30D70	PL183Y-300-XX, PL283Y-300-XX	39.4



Amphenol Technical Products International GZ

签名 SIGNATURE		日期 DATE	UNLESS OTHERWISE SPECIFIED			PART NAME:	
制图 DRAWN	Sam	05/10/17	1) All dimensions are in metric(mm).	PwrLok 10mm 3POS Rcpt Conn		DWG NO:	
审核 CHECKED	Julie	05/10/17	2) Tolerances are as follows:	PL083-300-30		CUST PART #:	
批准 APPROVAL	Haley	05/10/17	0 PL DEC ±1.00 1 PL DEC ±0.50 2 PL DEC ±0.20	N/A		CUST REV.:	
			Angles ±1°				

THIS DRAWING IS SUPPLIED FOR INFORMATION ONLY. DESIGN FEATURES, SPECIFICATIONS AND PERFORMANCE DATA SHOWN HEREON ARE THE PROPERTY OF THE AMPHENOL CORPORATION. NO RIGHTS OF REPRODUCTION ARE IMPLIED. ALL DIMENSIONS ARE SUBJECT TO NORMAL MANUFACTURING VARIATIONS.

Customer Drawing

Amphenol TPI
2018-08-22
REGISTERED COPY

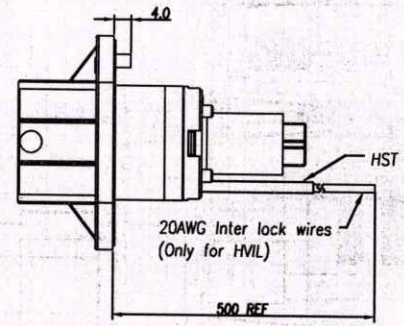
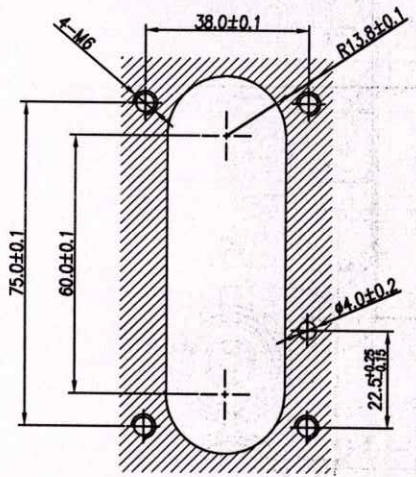
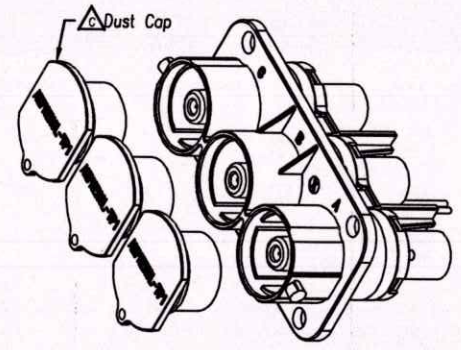
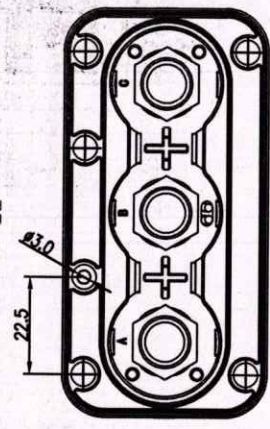
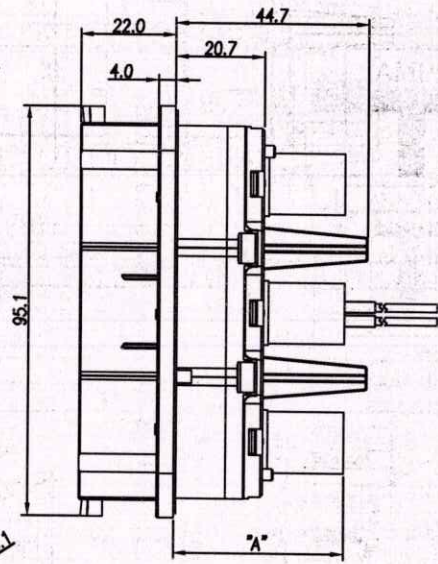
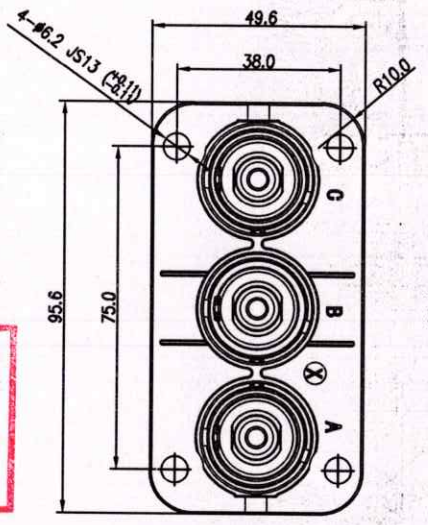

REVISIONS					
REV	ZONE	ECO	DESCRIPTION	DATE	BY APPR
A	---	---	INITIAL RELEASE	01/06/15	RW EC
B	---	---	Add Protection Class: IP2X	05/05/15	RW EC
C	---	---	Add Dust Cap & Change IML Wire, Update Spec.	03/29/16	RW TS
D	---	---	Change Shell and Gasket	05/10/17	Sam Julie

Standard Part List (With HVIL)

P/N	Model NO.	Mating Plug Model NO.	Dimension "A"
AC-HA001572	PL083X-301-30D35	PL183X-301-XX, PL283X-301-XX	36.4
AC-HA001573	PL083Y-301-30D35	PL183Y-301-XX, PL283Y-301-XX	36.4
AC-HA001574	PL083X-301-30D50	PL183X-301-XX, PL283X-301-XX	39.4
AC-HA001575	PL083Y-301-30D50	PL183Y-301-XX, PL283Y-301-XX	39.4
AC-HA001576	PL083X-301-30D70	PL183X-301-XX, PL283X-301-XX	39.4
AC-HA001577	PL083Y-301-30D70	PL183Y-301-XX, PL283Y-301-XX	39.4

Standard Part List (With Out HVIL)

P/N	Model NO.	Mating Plug Model NO.	Dimension "A"
AC-HA001578	PL083X-300-30D35	PL183X-300-XX, PL283X-300-XX	36.4
AC-HA001579	PL083Y-300-30D35	PL183Y-300-XX, PL283Y-300-XX	36.4
AC-HA001580	PL083X-300-30D50	PL183X-300-XX, PL283X-300-XX	39.4
AC-HA001581	PL083Y-300-30D50	PL183Y-300-XX, PL283Y-300-XX	39.4
AC-HA001582	PL083X-300-30D70	PL183X-300-XX, PL283X-300-XX	39.4
AC-HA001583	PL083Y-300-30D70	PL183Y-300-XX, PL283Y-300-XX	39.4

规格参数 (Spec.):

- 工作温度 Operating temperature: -40° C ~ +125° C.
- 带高压互锁 Electrical interlock (HVIL).
- 额定电流 Current rating: Power: 300A; HVIL: 5A.
- 额定电压 Operating voltage: Power: 1000 VDC; Signal: 60 VDC.
- 耐电压 Dielectric withstanding voltage:
 - 与插头对插后, Pin与铁壳之间 After mating, between pin and metal shell :5000 VDC.
 - 与插头对插后, Pin与HVIL之间 After mating, between pin and HVIL :5000 VDC.
 - 与插头对插后, HVIL与铁壳之间 After mating, between HVIL and metal shell :500 VDC.
 - 与插头对插前, 两个HVIL端子之间耐压 Before mating, between two HVIL terminals :500 VDC.
- 防护等级 Protection class: IP67 & IP2X.
- 电磁屏蔽 Shielding.
- 机械寿命 Mating cycle: 50 Min.
- 带自动二次锁扣 Automatic secondary lock.
- 推荐法兰盘螺丝安装扭矩 Recommended Screw Assembly Torque on Flange : 6.2~7.6 Nm

订购信息 Ordering Information

PL083 X - 30 1 - 30 D 70

键位及颜色 Key	高压互锁 HVIL	线缆尺寸 Cable Size
"X" Key	0, 不带互锁 No HVIL	*70"=70mm ²
"Y" Key	1, 带互锁 With HVIL	*50"=50mm ²
		*35"=35mm ²

		Amphenol Technical Products International GZ			
		第三角投影 THIRD ANGLE PROJECTION	页面 SHEET 1 of 1	幅面 SIZE A3	版次 REV. D
签名 SIGNATURE: <i>Sam</i> 日期 DATE: 05/10/17 制图 DRAWN: <i>Sam</i> 审核 CHECKED: <i>Jing</i> 批准 APPROVAL: <i>Way</i>		日期 DATE: 05/10/17 日期 DATE: 05/10/17 日期 DATE: 05/10/17		UNLESS OTHERWISE SPECIFIED: 1) All dimensions are in metric (mm). 2) Tolerances are as follows: 0 PL DEC ±1.00 1 PL DEC ±0.50 2 PL DEC ±0.20 Angles ±1°	
		PwrLok 10mm 3POS Rcpt Conn P/N: PL083-300-30 N/A			

Freel 2018.12.21 2018.12.21