

THIS DRAWING IS SUPPLIED FOR INFORMATION ONLY. DESIGN FEATURES, SPECIFICATIONS AND PERFORMANCE DATA SHOWN HEREON ARE THE PROPERTY OF THE AMPHENOL CORPORATION. NO RIGHTS OF REPRODUCTION ARE IMPLIED. ALL DIMENSIONS ARE SUBJECT TO NORMAL MANUFACTURING VARIATIONS.

Customer Drawing

REVISIONS						
REV	ZONE	ECO	DESCRIPTION	DATE	BY	APPR
A	--	--	INITIAL RELEASE	07/16/14	RW	EC
E	--	--	Add Protection Class: IP2X	05/05/15	RW	EC
F	--	--	Add Dust Cap & Change HVIL Wire	03/30/16	RW	GX
G	--	--	Change Shell and Gasket	05/10/17	Sam	Julie

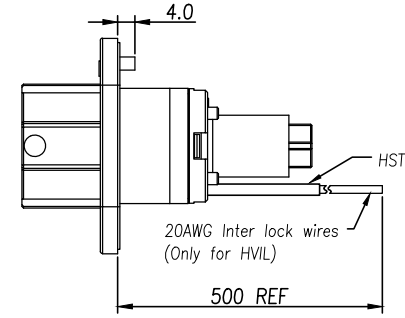
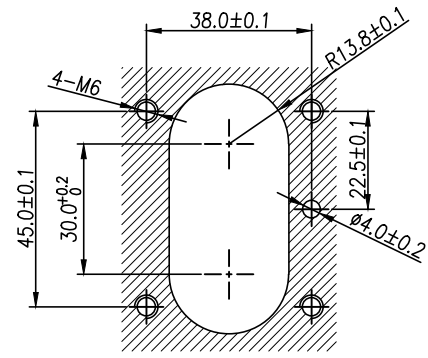
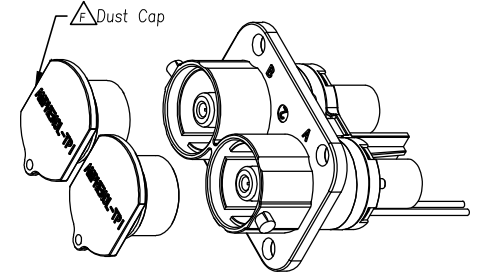
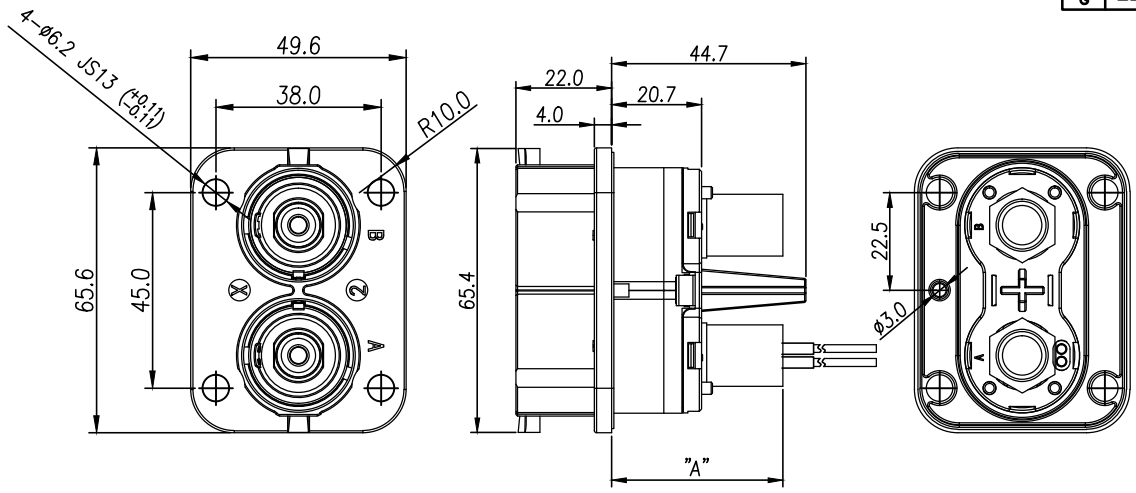

Standard Part List (With HVIL)

P/N	Model NO.	Dimension "A"
AC-HA001560	PL082X-301-30D35	36.4
AC-HA001561	PL082Y-301-30D35	36.4
AC-HA001562	PL082X-301-30D50	39.4
AC-HA001563	PL082Y-301-30D50	39.4
AC-HA001564	PL082X-301-30D70	39.4
AC-HA001565	PL082Y-301-30D70	39.4

Standard Part List (Without HVIL)

P/N	Model NO.	Dimension "A"
AC-HA001566	PL082X-300-30D35	36.4
AC-HA001567	PL082Y-300-30D35	36.4
AC-HA001568	PL082X-300-30D50	39.4
AC-HA001569	PL082Y-300-30D50	39.4
AC-HA001570	PL082X-300-30D70	39.4
AC-HA001571	PL082Y-300-30D70	39.4

规格参数 (Spec.):

1. 工作温度 Operating temperature: -40° C ~ +125° C.
2. 带高压互锁 Electrical interlock (HVIL).
3. 额定电流 Current rating: Power: 300A; HVIL: 5A.
4. 额定电压 Operating voltage: Power: 1000 VDC; Signal: 60 VDC.
5. 耐电压 Dielectric withstanding voltage:
 - A. 与插头对插后, Pin与铁壳之间 After mating, between pin and metal shell :5000 VDC.
 - B. 与插头对插后, Pin与HVIL之间 After mating, between pin and HVIL :5000 VDC.
 - C. 与插头对插后, HVIL与铁壳之间 After mating, between HVIL and metal shell :500 VDC.
 - D. 与插头对插前, 两个HVIL端子之间耐压 Before mating, between two HVIL terminals :500 VDC.
6. 防护等级 Protection class: IP67 & IP2X.
7. 电磁屏蔽 Shielding.
8. 机械寿命 Mating cycle: 50 Min.
9. 带自动二次锁扣 Automatic secondary lock.
10. 推荐法兰盘螺丝安装扭矩: Recommended Screw Assembly Torque on Flange : 6.2~7.6 Nm

面板安装孔尺寸 Panel Size

订购信息 Ordering Information

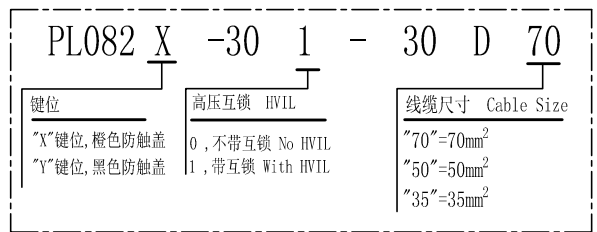

		Amphenol Technical Products International GZ				PART NAME:	
		第三角投影 THIRD ANGLE PROJECTION	页面 SHEET	幅面 SIZE	版次 REV.	比例 SCALE	PwrLok 10mm 2POS Rcpt Conn
签名 SIGNATURE		日期 DATE	UNLESS OTHERWISE SPECIFIED			DWG NO:	
制图 DRAWN	Sam	05/10/17	1) All dimensions are in metric(mm).			PL082-300-30	
审核 CHECKED	Julie	05/10/17	2) Tolerances are as follows:			CUST PART #:	
批准 APPROVAL	Haley	05/10/17	0 PL DEC ±1.00 1 PL DEC ±0.50 2 PL DEC ±0.20			N/A	
			Angles ±1°			CUST REV.:	
						-	

THIS DRAWING IS SUPPLIED FOR INFORMATION ONLY. DESIGN FEATURES, SPECIFICATIONS AND PERFORMANCE DATA SHOWN HEREON ARE THE PROPERTY OF THE AMPHENOL CORPORATION. NO RIGHTS OF REPRODUCTION ARE IMPLIED. ALL DIMENSIONS ARE SUBJECT TO NORMAL MANUFACTURING VARIATIONS.

Customer Drawing

REVISIONS					
REV	ZONE	ECO	DESCRIPTION	DATE	BY APPR
A	---	---	INITIAL RELEASE	07/16/14	RW EC
E	---	---	Add Protection Class: IP2X	05/05/15	RW EC
F	---	---	Add Dust Cap & Change HVL Wire	03/30/16	RW GX
G	---	---	Change Shell and Gasket	05/10/17	Sam Julie

Amphenol TPI
2018-08-22
REGISTERED COPY

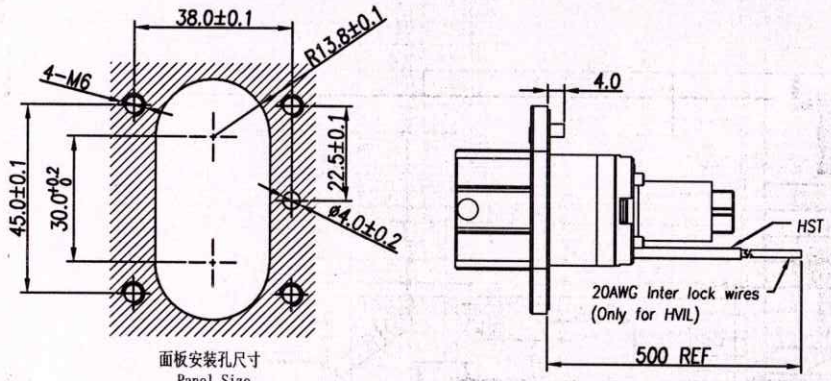
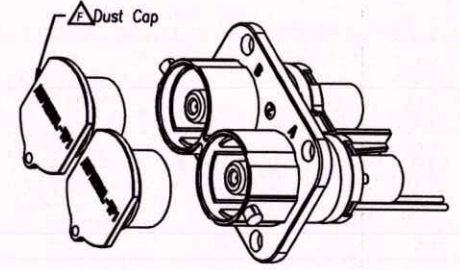
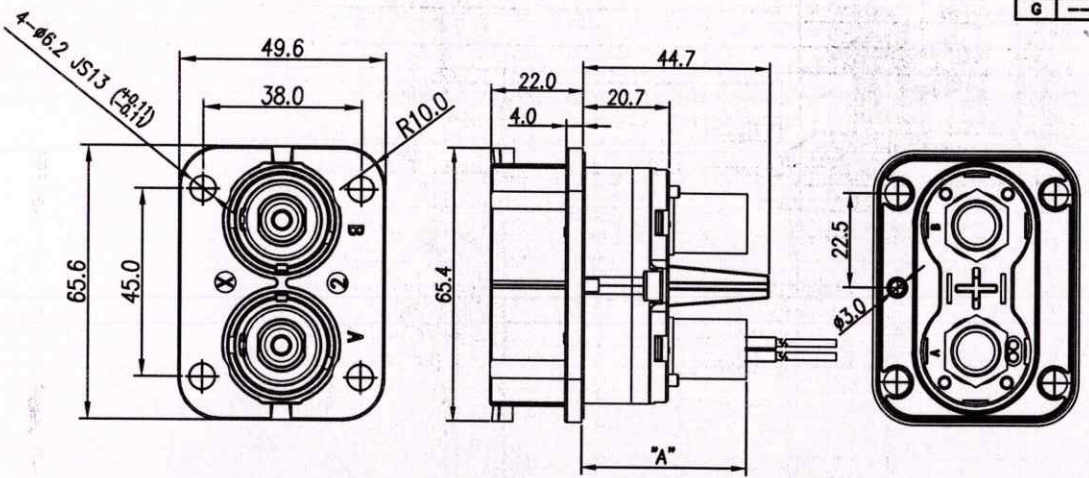

Standard Part List (With HVIL)

P/N	Model NO.	Dimension "A"
AC-HA001560	PL082X-301-30D35	36.4
AC-HA001561	PL082Y-301-30D35	36.4
AC-HA001562	PL082X-301-30D50	39.4
AC-HA001563	PL082Y-301-30D50	39.4
AC-HA001564	PL082X-301-30D70	39.4
AC-HA001565	PL082Y-301-30D70	39.4

Standard Part List (Without HVIL)

P/N	Model NO.	Dimension "A"
AC-HA001566	PL082X-300-30D35	36.4
AC-HA001567	PL082Y-300-30D35	36.4
AC-HA001568	PL082X-300-30D50	39.4
AC-HA001569	PL082Y-300-30D50	39.4
AC-HA001570	PL082X-300-30D70	39.4
AC-HA001571	PL082Y-300-30D70	39.4

- 规格参数 (Spec.):
- 工作温度 Operating temperature:
-40° C ~ +125° C.
 - 带高压互锁 Electrical interlock (HVIL).
 - 额定电流 Current rating:
Power: 300A; HVIL: 5A.
 - 额定电压 Operating voltage:
Power: 1000 VDC; Signal: 60 VDC.
 - 耐电压 Dielectric withstanding voltage:
 - 与插头对插后, Pin与铁壳之间
After mating, between pin and metal shell : 5000 VDC.
 - 与插头对插后, Pin与HVIL之间
After mating, between pin and HVIL : 5000 VDC.
 - 与插头对插后, HVIL与铁壳之间
After mating, between HVIL and metal shell : 500 VDC.
 - 与插头对插前, 两个HVIL端子之间耐压
Before mating, between two HVIL terminals : 500 VDC.
 - 防护等级 Protection class: IP67 & IP2X.
 - 电磁屏蔽 Shielding.
 - 机械寿命 Mating cycle: 50 Min.
 - 带自动二次锁扣 Automatic secondary lock.
 - 推荐法兰盘螺丝安装扭矩 Recommended Screw Assembly Torque on Flange : 6.2 ~ 7.6 Nm

面板安装孔尺寸
Panel Size

订购信息 Ordering Information

PL082 X -30 1 - 30 D 70

键位	高压互锁 HVIL	线缆尺寸 Cable Size
"X"键位, 橙色防触盖	0, 不带互锁 No HVIL	"70"=70mm ²
"Y"键位, 黑色防触盖	1, 带互锁 With HVIL	"50"=50mm ²
		"35"=35mm ²

AMPHENOL

Amphenol Technical Products International GZ

第三角投影 THIRD ANGLE PROJECTION	页面 SHEET	幅面 SIZE	版次 REV.	比例 SCALE	PART NAME PartLok 10mm 2POS Rcpt Conn
◆	1 of 1	A3	G		DRAWN PL082-300-30
签名 SIGNATURE: Sam 日期 DATE: 05/10/17 制图 DRAWN: Sam 审核 CHECKED: Julie 批准 APPROVAL: Julie					UNLESS OTHERWISE SPECIFIED: 1) All dimensions are in metric (mm). 2) Tolerances are as follows: 0 PL DEC ±1.00 1 PL DEC ±0.80 2 PL DEC ±0.50 Angles ±1°
					CURT PART # N/A

Fred 2018-8-21 10:46:51 2186521