

THIS DRAWING IS SUPPLIED FOR INFORMATION ONLY. DESIGN FEATURES, SPECIFICATIONS AND PERFORMANCE DATA SHOWN HEREON ARE THE PROPERTY OF THE AMPHENOL CORPORATION. NO RIGHTS OF REPRODUCTION ARE IMPLIED. ALL DIMENSIONS ARE SUBJECT TO NORMAL MANUFACTURING VARIATIONS.

Customer Drawing

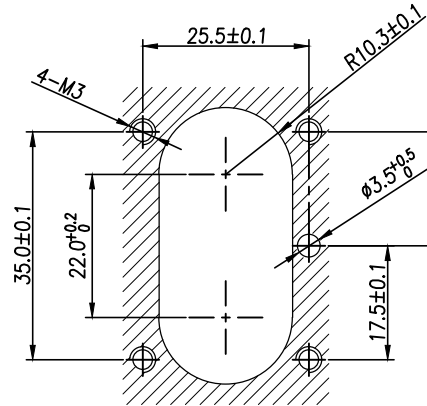

面板安装孔尺寸
Panel Size

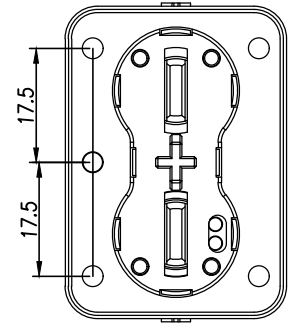
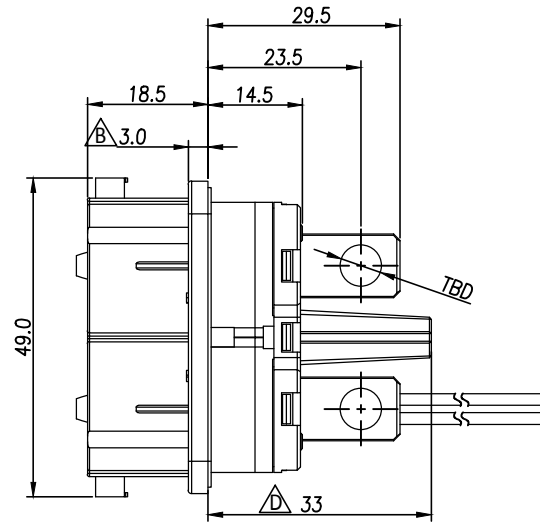
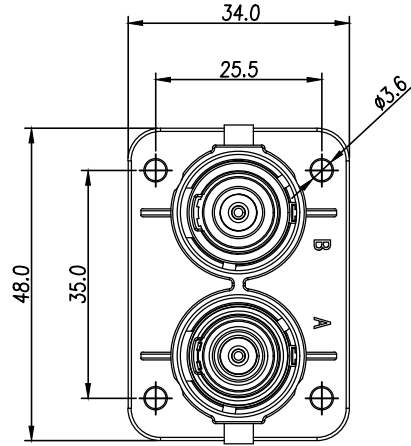
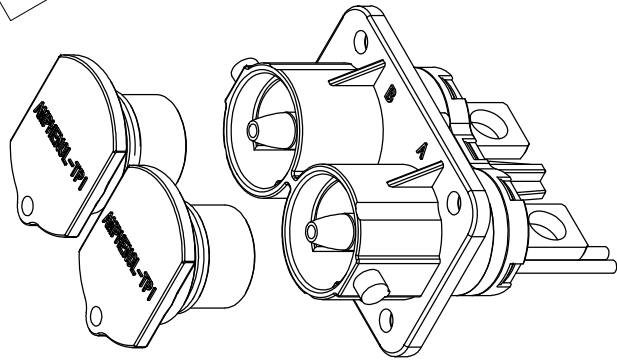
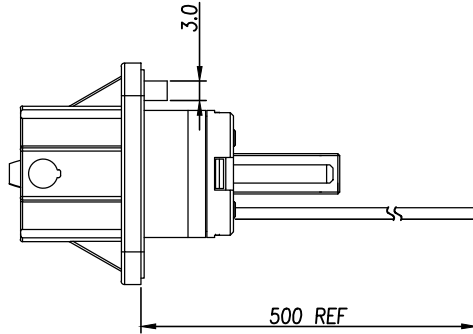

订购信息 Ordering Information

PL082	X	-	12	0	-	10	D	6
键位及颜色 Key & Color	高压互锁 HVIL	孔种类 Hole Type	联接螺栓 Bolt Size					
"X", 橙色 Orange	0, 不带互锁 No HVIL	D, 通孔 Through Hole	Customer Define					
"Y", 黑色 Black	1, 带互锁 With HVIL	M, 螺纹孔 Screw Hole						

规格参数 (Spec.):

- 工作温度 Operating temperature: -40° C~+125° C.
- 带高压互锁 Electrical interlock (HVIL).
- 额定电流 Current rating: Power: 120A; HVIL: 5A.
- 额定电压 Operating voltage: Power: 1000 VDC; Signal: 60 VDC.
- 耐电压 Dielectric withstanding voltage:
 - 与插头对插后, Pin与铁壳之间
After mating, between pin and metal shell :5000 VDC.
 - 与插头对插后, Pin与HVIL之间
After mating, between pin and HVIL :5000 VDC.
 - 与插头对插后, HVIL与铁壳之间
After mating, between HVIL and metal shell :500 VDC.
 - 与插头对插前, 两个HVIL端子之间耐压
Before mating, between two HVIL terminals :500 VDC.
- 防护等级 Protection class: IP67 & IP2X.
- 电磁屏蔽 Shielding.
- 机械寿命 Mating cycle: 500 Min.
- 带自动二次锁扣 Automatic secondary lock.
- 铜排推荐安装扭矩 Recommended Fasten Torque on Lug: M6 : 3.6~4.4 Nm
- 推荐法兰盘螺丝安装扭矩 Recommended Screw Assembly Torque on Flange : 0.86±20% Nm

		Amphenol Technical Products International Asia.				PART NAME: PwrLok 5.7mm 2POS Rcpt Lug Assy	
		第三角投影 THIRD ANGLE PROJECTION	页面 SHEET	幅面 SIZE	版次 REV.	比例 SCALE	DWG NO: PL082-120-10
签名 SIGNATURE	日期 DATE	UNLESS OTHERWISE SPECIFIED			CUST PART #:		
制图 DRAWN	KW	1) All dimensions are in metric(mm).			N/A		
审核 CHECKED	JC	2) Tolerances are as follows:			CUST REV.:		
批准 APPROVAL	JL	0 PL DEC ±1.00			-		
		1 PL DEC ±0.50					
		2 PL DEC ±0.20					
		Angles ±1°					