

THIS DRAWING IS SUPPLIED FOR INFORMATION ONLY. DESIGN FEATURES, SPECIFICATIONS AND PERFORMANCE DATA SHOWN HEREON ARE THE PROPERTY OF THE AMPHENOL CORPORATION. NO RIGHTS OF REPRODUCTION ARE IMPLIED. ALL DIMENSIONS ARE SUBJECT TO NORMAL MANUFACTURING VARIATIONS.

Customer Drawing

REVISIONS					
REV	ZONE	ECO	DESCRIPTION	DATE	BY APPR
A	--	--	Change HVIL Wire & Dust Cap, Update Spec.	03/31/16	RW TS

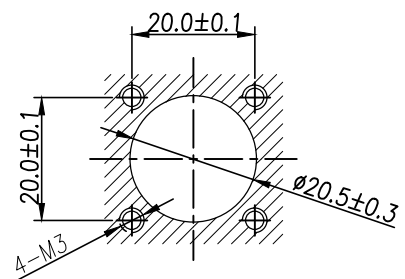
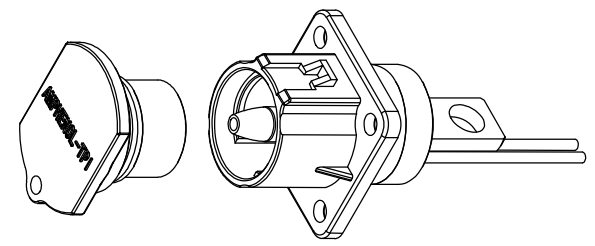
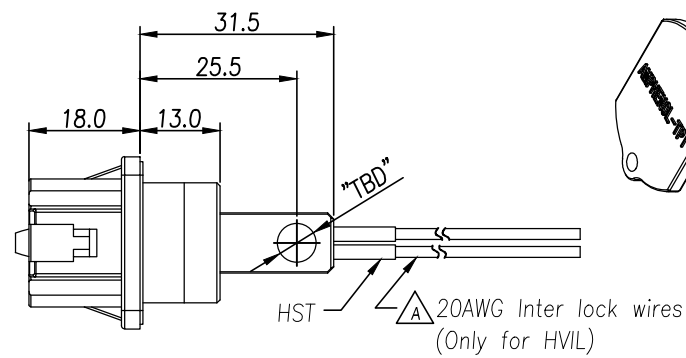
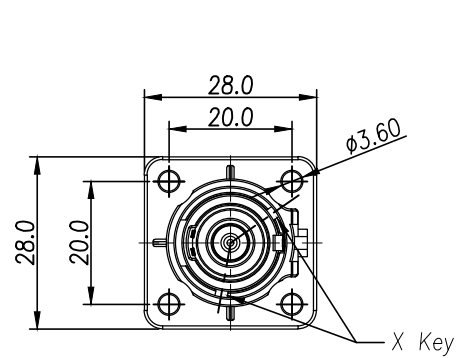

面板安装孔尺寸  
Panel Size

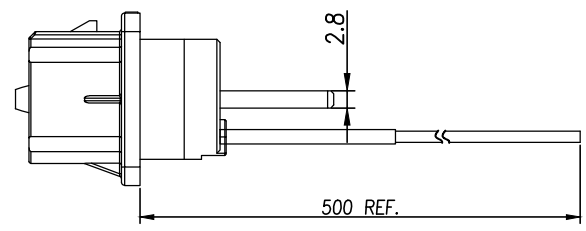

Standard Part List

P/N	Model NO.	Polarization
AC-HA000469	PL00X-120-10D6	X
AC-HA000470	PL00Y-120-10D6	Y
AC-HA000471	PL00U-120-10D6	U
AC-HA000472	PL00V-120-10D6	V
AC-HA000473	PL00W-120-10D6	W
AC-HA000479	PL00X-120-10M6	X
AC-HA000480	PL00Y-120-10M6	Y
AC-HA000481	PL00U-120-10M6	U
AC-HA000482	PL00V-120-10M6	V
AC-HA000483	PL00W-120-10M6	W

Standard Part List (With HVIL)

P/N	Model NO.	Polarization
AC-HA000305	PL00X-121-10D6	X
AC-HA000306	PL00Y-121-10D6	Y
AC-HA000307	PL00U-121-10D6	U
AC-HA000308	PL00V-121-10D6	V
AC-HA000309	PL00W-121-10D6	W
AC-HA000459	PL00X-121-10M6	X
AC-HA000460	PL00Y-121-10M6	Y
AC-HA000461	PL00U-121-10M6	U
AC-HA000462	PL00V-121-10M6	V
AC-HA000463	PL00W-121-10M6	W

The Key of Angle

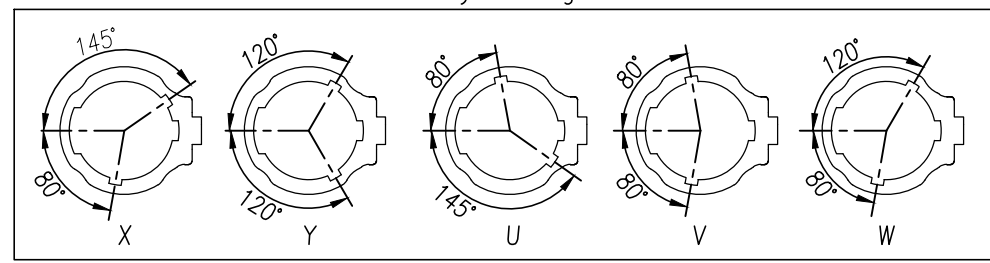

规格参数 (Spec.):

- 工作温度 Operating temperature: -40° C ~ +125° C.
- 带高压互锁 Electrical interlock (HVIL).
- 额定电流 Current rating: Power: 120A; HVIL: 5A.
- 额定电压 Operating voltage: Power: 1000 VDC; Signal: 60 VDC.
- 耐电压 Dielectric withstanding voltage:
  - 与插头对插后, Pin与铁壳之间  
After matting, between pin and metal shell :5000 VDC.
  - 与插头对插后, Pin与HVIL之间  
After matting, between pin and HVIL :5000 VDC.
  - 与插头对插后, HVIL与铁壳之间  
After matting, between HVIL and metal shell :500 VDC.
  - 与插头对插前, 两个HVIL端子之间耐压  
Before matting, between two HVIL terminals :500 VDC.
- 防护等级 Protection class: IP67 & IP2X.
- 电磁屏蔽 Shielding.
- 机械寿命 Mating cycle: 500 Min.
- 带自动二次锁扣 Automatic secondary lock.
- 铜排推荐安装扭矩 Recommended Fasten Torque on Lug: M6 : 3.6~4.4 Nm
- 推荐法兰盘螺丝安装扭矩 Recommended Screw Assembly Torque on Flange : 0.86±20% Nm

订购信息 Ordering Information

PL00 X - 12 0 - 10 D 6

键位及颜色 Key & Color	高压互锁 HVIL	孔种类 Hole Type	联接螺栓 Bolt Size
"X", 橙色 Orange "Y", 黑色 Black "U", 黄色 Yellow "V", 绿色 Green "W", 红色 Red	0, 不带互锁 No HVIL 1, 带互锁 With HVIL	D, 通孔 Through Hole M, 螺纹孔 Screw Hole	Customer Define

	Amphenol Technical Products International GZ				
	第三角投影 THIRD ANGLE PROJECTION	页面 SHEET	幅面 SIZE	版次 REV.	比例 SCALE
签名 SIGNATURE	日期 DATE	UNLESS OTHERWISE SPECIFIED			DWG NO: PL00-120-10
制图 DRAWN	RW	1 of 1	A3	A	-
审核 CHECKED	GX	1) All dimensions are in metric(mm). 2) Tolerances are as follows: 0 PL DEC ±1.00 1 PL DEC ±0.50 2 PL DEC ±0.20			CUST PART #: N/A
批准 APPROVAL	EC	09/18/13	09/18/13	09/18/13	Angles ±1°
					CUST REV. -